

Canopy
Mini Pure'line 90 cm
Stainless steel

EAN 5414425008209



Energy label

▪ Energy Efficiency class (EEI)	A+
▪ Annual Energy Consumption (kWh/year) (AEC _{hood})	29,1
▪ Fluid Dynamic Efficiency class (FDE _{hood})	A
▪ Lighting Efficiency class (LE _{hood})	A
▪ Grease Filtering Efficiency class (GFE _{hood})	D

Functions & features

▪ Control method	Push buttons + Remote control
▪ Number of speeds	3 + power
▪ Automatic Power revert (minutes)	6
▪ Motor	Integrated
▪ Sound absorber	Integrated
▪ Recirculation	Optional
▪ InTouch function	Standard
▪ Auto stop	▪
▪ Delayed switch off (minutes)	10
▪ Number of grease filters	1
▪ Grease filter	7400020
▪ Grease filter cleaning indication	▪
▪ Recirculation filter cleaning indication	▪

Dimensions

▪ Product dimensions (WxDxH) (mm)	860 x 301 x 330
▪ Width flange (mm)	10
▪ Dimensions cut-out opening (WxD) (mm)	845 x 286
▪ Advised mounting height ceramic hobs (H _{min} -H _{max}) (mm)	600 - 750
▪ Advised mounting height gas and induction hobs (H _{min} -H _{max}) (mm)	650 - 750
▪ Diameter outlet (mm)	150
▪ Position exhaust	Right, Top, Left, Back, Front

Lighting

▪ Functional lighting type	Led
▪ Dimmable light	▪
▪ Soft-ON/OFF	▪
▪ Total energy consumption functional light (W)	8

Airflow and noise level

▪ Airflow (m ³ /h) measured according to EN 61591	
▪ Sound regulation according to EN 60704-2-13	
▪ Airflow speed 1 (m ³ /h) / Max Pressure speed 1 (Pa)	253 / 77
▪ Airflow speed 2 (m ³ /h) / Max Pressure speed 2 (Pa)	425 / 263
▪ Airflow speed 3 (m ³ /h) / Max Pressure speed 3 (Pa)	563 / 382

Airflow and noise level

▪ Airflow Powerspeed (m ³ /h) / Max Pressure Powerspeed (Pa)	655 / 383
▪ Sound power speed 1 (dB(A)) / Sound pressure speed 1 (dB(A))	36 / 27
▪ Sound power speed 2 (dB(A)) / Sound pressure speed 2 (dB(A))	49 / 38
▪ Sound power speed 3 (dB(A)) / Sound pressure speed 3 (dB(A))	57 / 46
▪ Sound Powerspeed (dB(A)) / Sound pressure Powerspeed (dB(A))	60 / 49

Technical specifications

▪ Maximum power	118
▪ Voltage (V)	220-230
▪ Frequency (Hz)	50
▪ Power consumption in stand-by-mode (W)	0,31

1

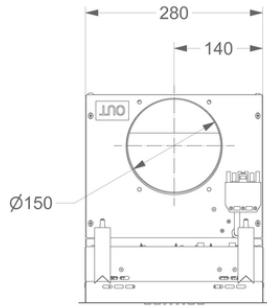

2

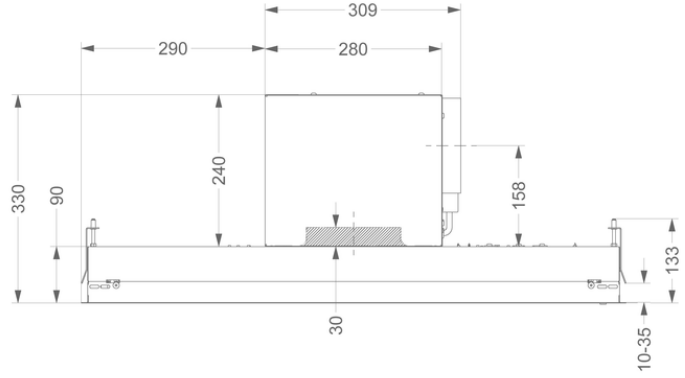

3

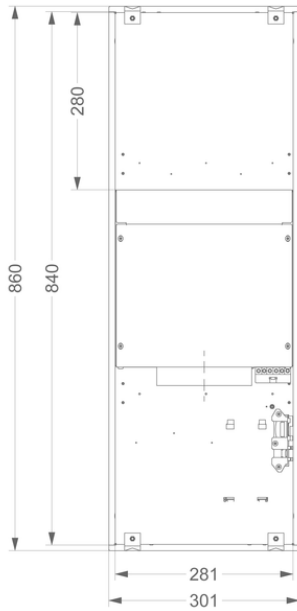

4

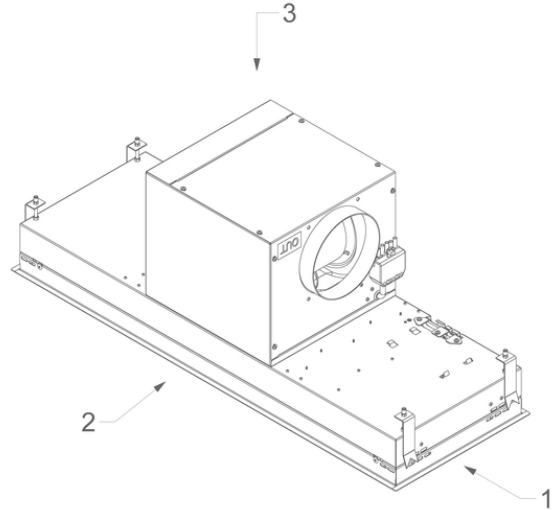

Installation accessories

Dissociated motor

- 800998

Dissociated motor

Extension cable

- 700094

Extension cable 5 m

Accessories

Recirculation kit



820400

Kit with monoblock filter

Recirculation box



830400

Recirculation box inox with monoblock filter



831400

Recirculation box white with monoblock filter



7900400

Recirculation box inox with monoblock filter 14 cm

Adapter for limited installation height



830052

Adapter limited installation height 18,3 cm

Control kit



990030

Control kit for external lighting or valve

Efficiency Curve

